

# DATA SHEET

## Vertical copper-bonded forged rod with sealing-strengthening bush

The 99.9% pure electrolytic copper bonded onto a drawn steel to a thickness of **min 0.250 mm** forms molecular and inseparable connection with the steel. The steel core has a high tensile strength of 600 N/mm<sup>2</sup>.

One end of the rod has decreased diameter by cold pressed this guarantees the same thickness of the copper layer on the whole length of the rod. The other end has a hole which enables the connection between the rods to increase the length.

The connection of the rods is protected by sealing bush made of stainless steel which provides additional mechanical strength to the connection. The rod pin is made by cold pressed this hardened the end of rod. Therefore there is no need to use the tip. Connection of the rods complies with the requirements of IEC/EN 62561-2 „Lightning protection components (LPSC). Requirements for conductors and earth electrodes”. To drive the rod into the ground, the driving stud and tup for mechanical driving or tup for hand driving must be used.

The sealing bush advantage:

- sealing the pin-feather key connection,
- strengthening the mechanical connection

### Vertical copper-bonded forged rod with sealing-strengthening bush

Cat. no.	Diameter of rod mm	Length* m	Material
C0000172	14.2	1.2	steel copper-bonded to thickness of 0.250 mm, sealing-strengthening steel bush
C0000175	14.2	1.5	
C0000195	16.0	1.5	
C0000185	17.2	1.5	

\* for special orders we supply different rod lengths up to 3 m

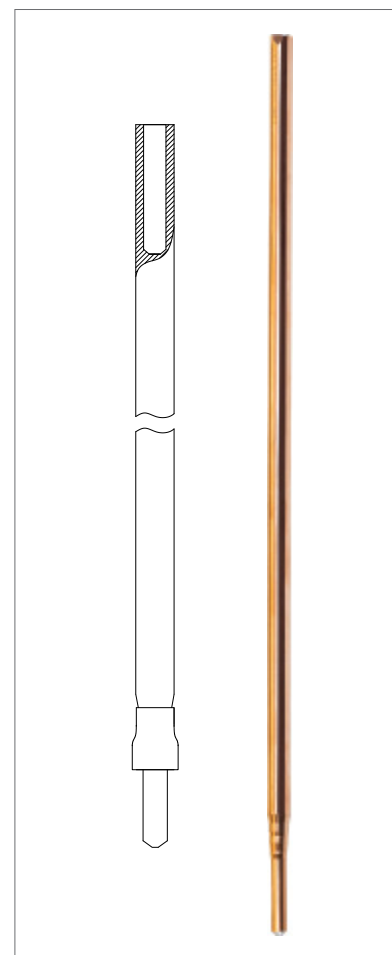

**CBM Technology Sp. z o.o.**

ul. Kasztanowa 2, 64-320 Niepruszewo, Poland

tel. +48/61 650 30 40

e-mail: office@cbm-technology.eu; www.cbm-technology.eu

# DATA SHEET

## Driving stud for forged rod

Driving stud is to transfer the vibrations from the tup to earth rod. It should be placed in the feather key of the rod and should be imbeded with the hammer

Cat. no.	Diameter of rod mm	Material
C1080175	14.2	steel
C1080195	16.0	
C1080185	17.2	

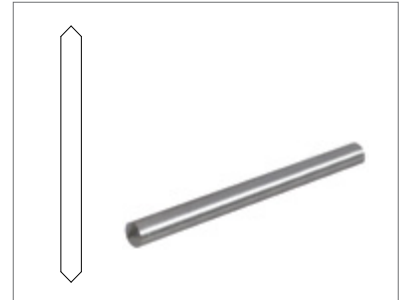

## The driving stud stabilizer to embed forged rods

The driving stud stabilizer makes it possible for the driving stud to be stroke centrally in the forged rod core when grounding

Cat. no.	Diameter of rod mm	Material
C1070375	14.2	teflon
C1070395	16.0	
C1070385	17.2	

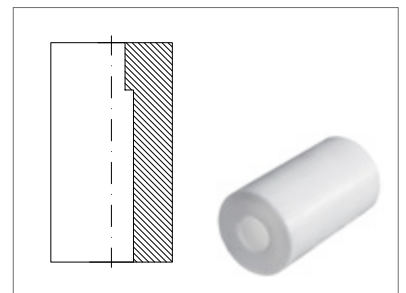

## Tup for forged rod

Tup for forged rod transfers vibrations from the percussive hammer or hand hammer onto earth rod core through the driving stud placed in the feather key of the rod

Cat. no.	Diameter of rod mm	Application
C1090375	14.2; 16.0	for mechanical driving using hammers with SDS-Max fastening
C1090376		for hand driving
C1090377		for mechanical driving with Hilti TE 905 and TE 1000
C1090385	17.2	for mechanical driving using hammers with SDS-Max fastening
C1090386		for hand driving
C1090387		for mechanical driving with Hilti TE 905 and TE 1000

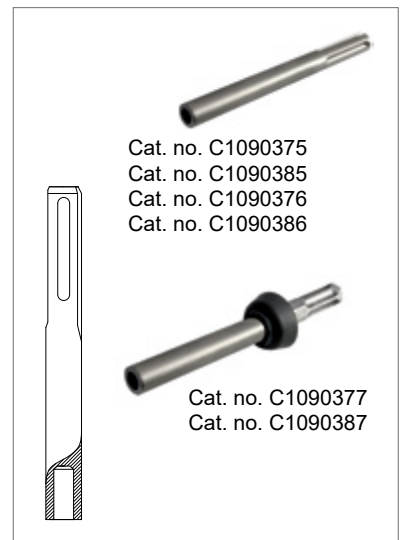

### CBM Technology Sp. z o.o.

ul. Kasztanowa 2, 64-320 Niepruszewo, Poland

tel. +48/61 650 30 40

e-mail: office@cbm-technology.eu; www.cbm-technology.eu